

Pharmacokinetic Issues

A Basic Refresher



ST. JAMES'S
HOSPITAL



Pharmacokinetics

φαρμακός (drug) + κινητικός (putting in motion)

- Term introduced in 1953.
 - Friedrich H Dost, *Der Blutspiegel: Kinetik der Konzentrationsabläufe in der Kreislaufflüssigkeit* (1953)
- *Pharmacokinetics* may be simply defined as what the body does to the drug, as opposed to *pharmacodynamics* which may be defined as what the drug does to the body.
 - Leslie Z Benet, *Pharmacokinetics: Basic Principles and Its Use as a Tool in Drug Metabolism* (1984)

Pharmacokinetic process

(L)ADME

- **Liberation**
 - Release & dissolution
- **Absorption**
 - Permeation (diffusion & transport)
- **Distribution**
 - Peripheral compartment(s)
- **Metabolisation**
 - Gut wall & first pass
- **Excretion**
 - Urine, feces, sweat, air,...

Absorption

Elimination

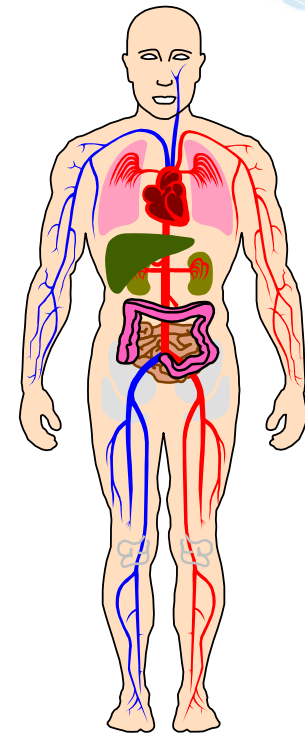

Pharmacokinetic process

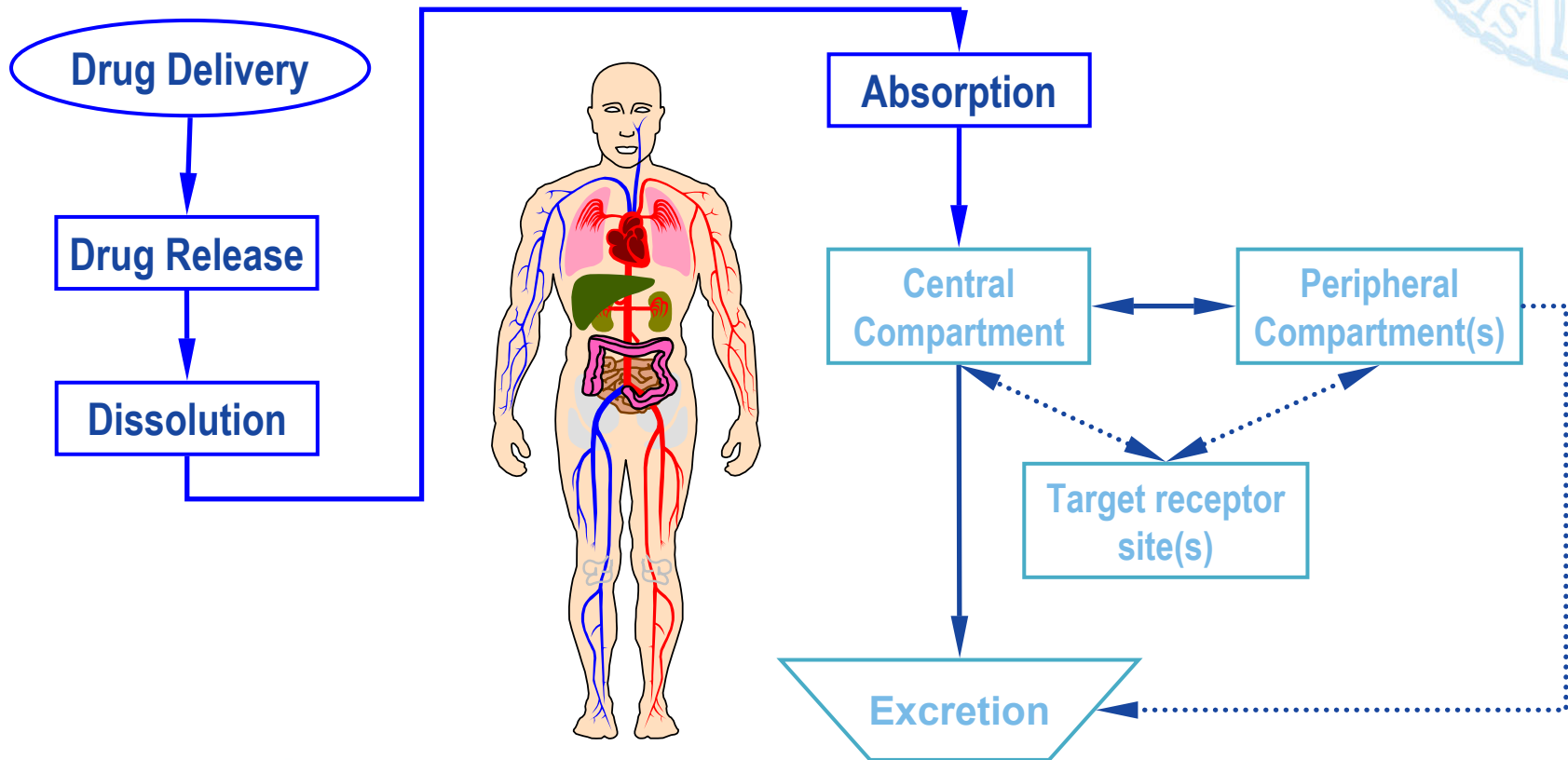

Pharmacokinetic process

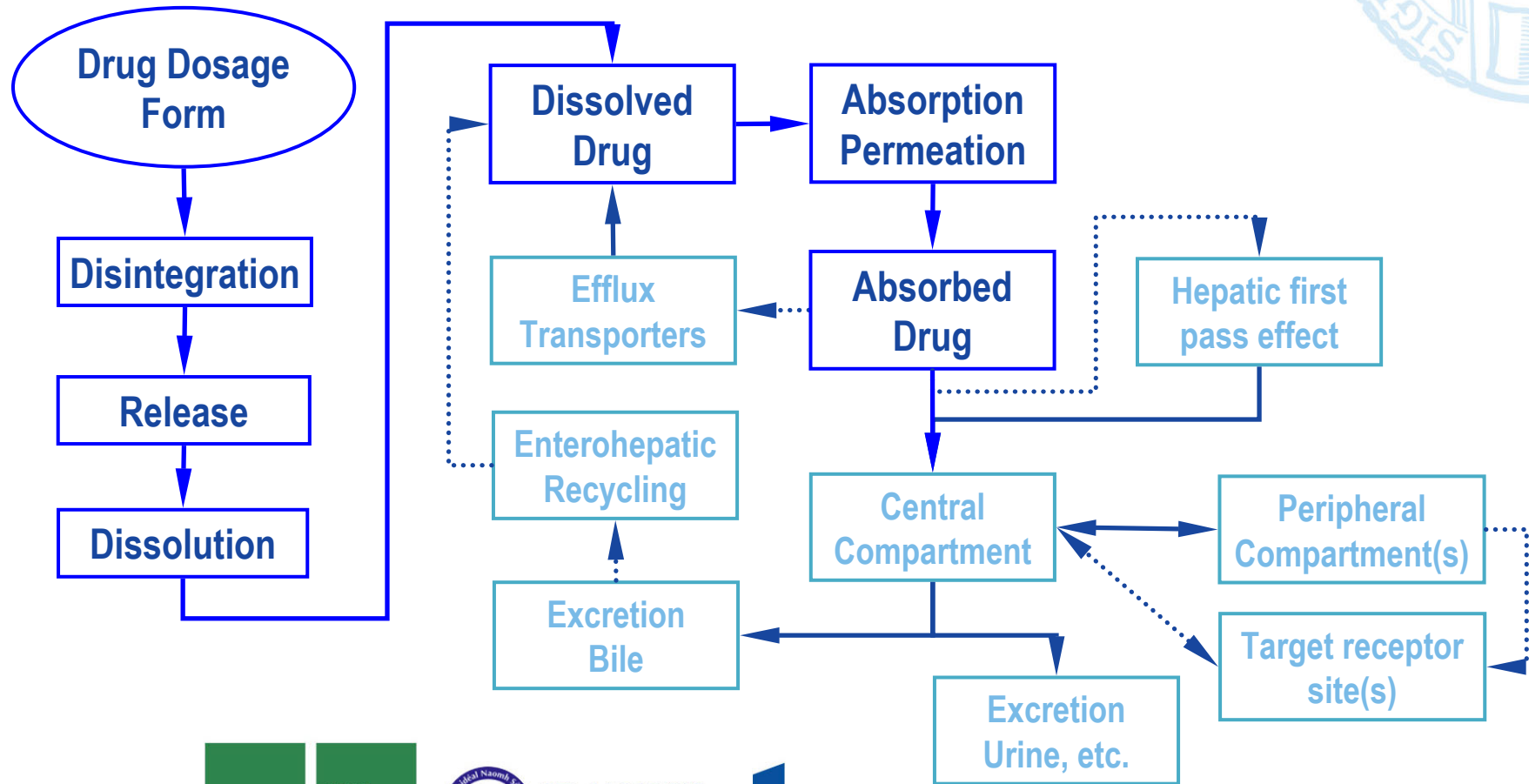

Pharmacokinetic process



Biopharmaceutical phase

- Disintegration
- Release
- Dissolution

Pharmacokinetic phase

- Absorption
 - Passive diffusion
 - Active transport
- Metabolism
 - Intestinal first pass
 - Membrane first pass
 - Hepatic first pass

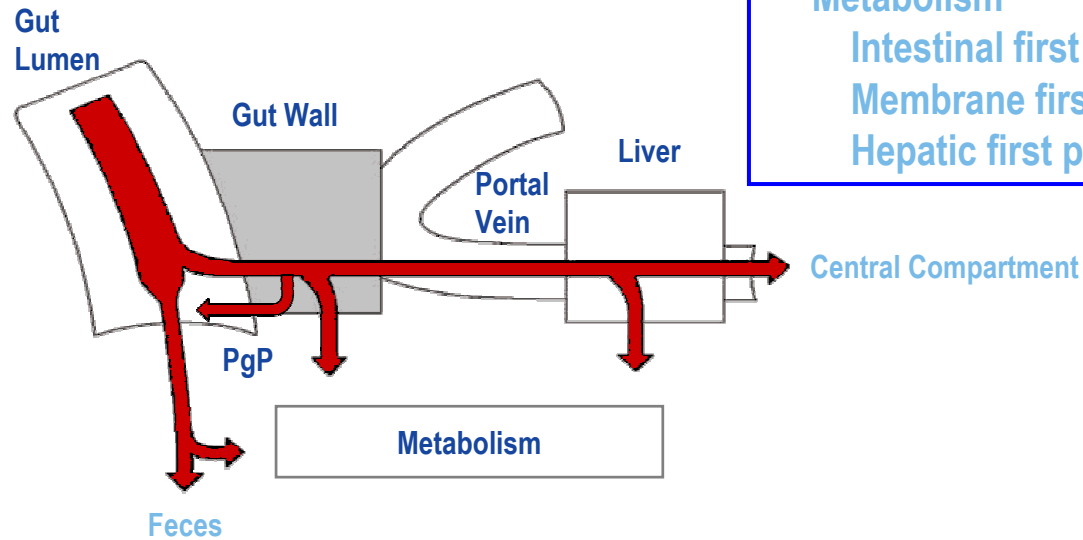

Pharmacokinetic process



Absorption revisited

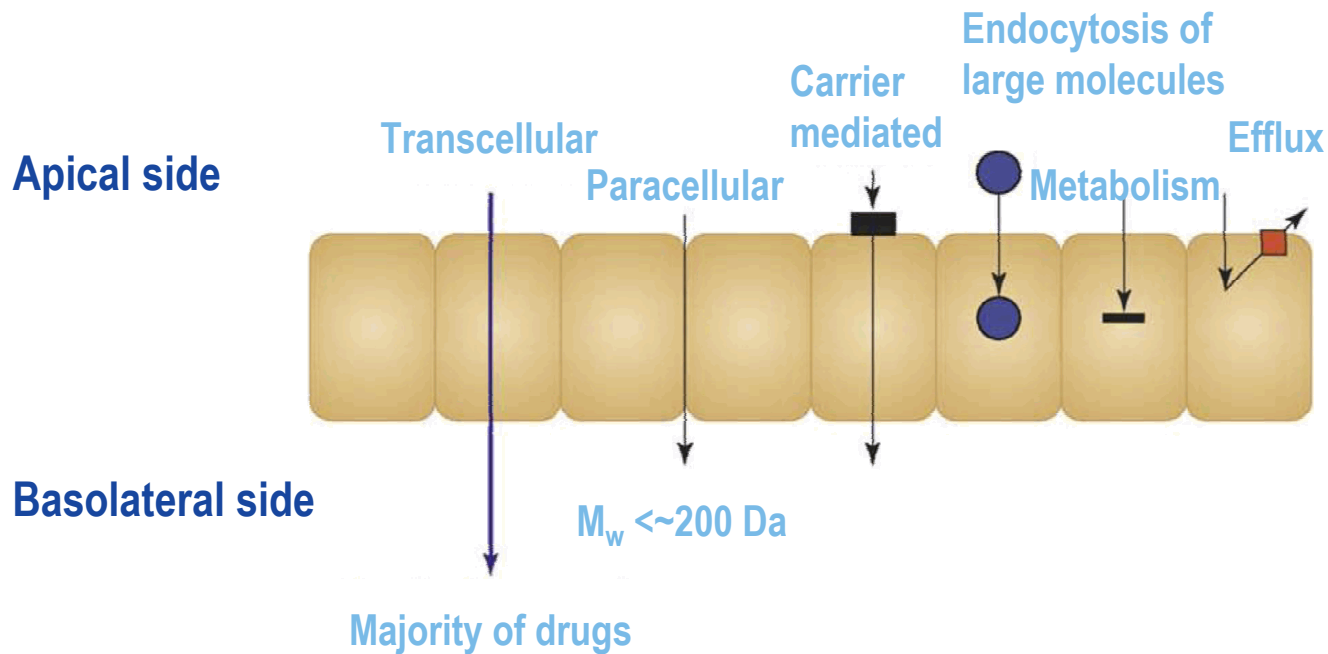

Pharmacokinetic models

The body is simplified to one – or more –
'Compartments' where the drug is distributed

- One compartment model
 - Drug is distributed homogeneously within the entire body.
- Two compartment model
 - The first (central) compartment is *loosely* related to the blood and heavily perfused organs: Liver, kidneys, lung, muscles, (brain).
 - The second (peripheral) compartment describes less perfused tissues (fat, bones, ...).

Pharmacokinetic models

Compartment models

- **Compartments are**
 - described by a volume and
 - pathways which link them.
- **These links may be**
 - unidirectional (absorption, excretion) or
 - bidirectional (central \leftrightarrow peripheral)
- **Most common models are ‘mammillary’, i.e.,**
 - absorption to the central compartment,
 - distribution to peripheral and back to the central compartment, and
 - elimination from the central compartment.

Pharmacokinetic models

Examples

One comp. IV

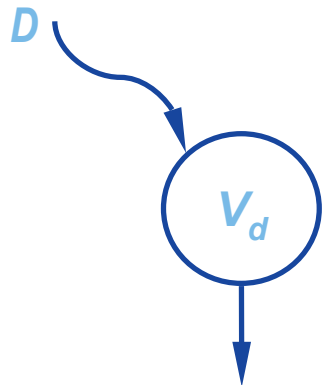

One comp. EV

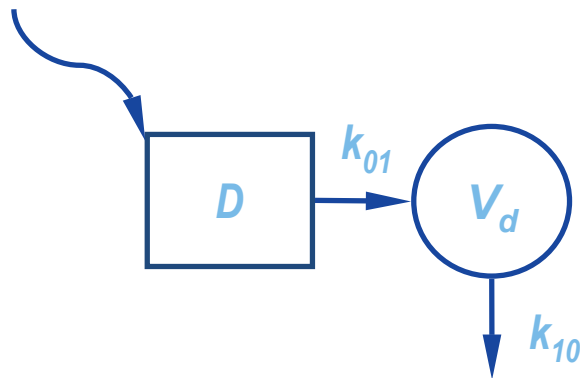

Two comp's EV

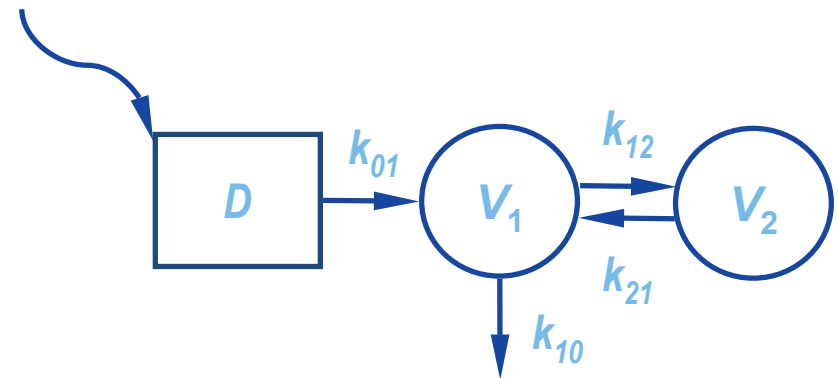

One compartment model, IV dose

Excursion into Hydrodynamics

- Driving force for draining an *open* tank: Hydrostatic pressure (height of liquid column & gravity).
- Emptied volume decreases with time.
- Same *proportion* is emptied in the same time interval.

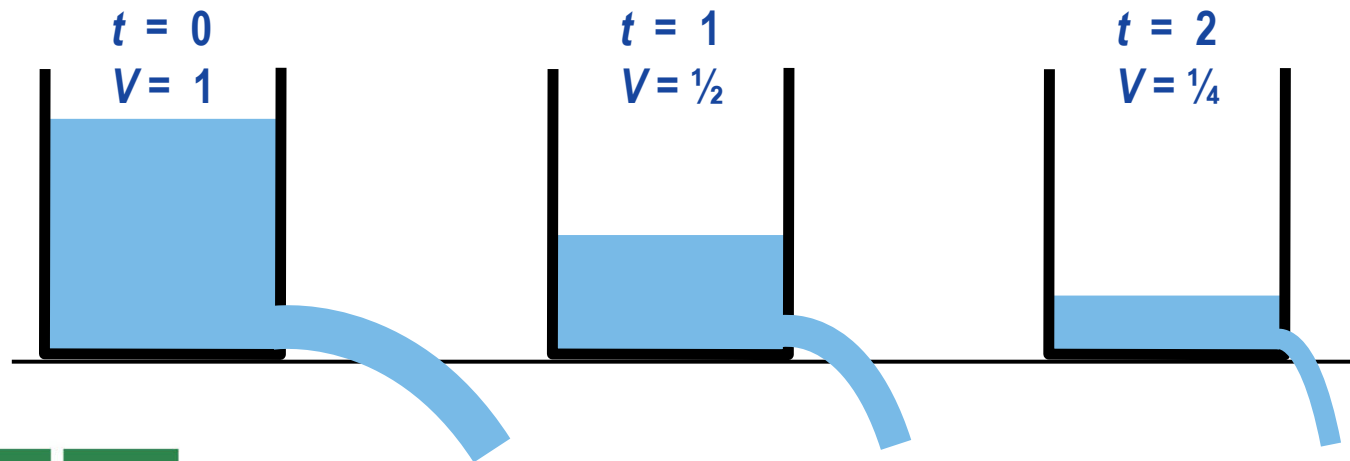

One compartment model, IV dose

The whole body is simplified to one 'compartment'

- Practically instantaneous distribution.
- Homogenous within all tissues.
- Concentrations decline exponentially.

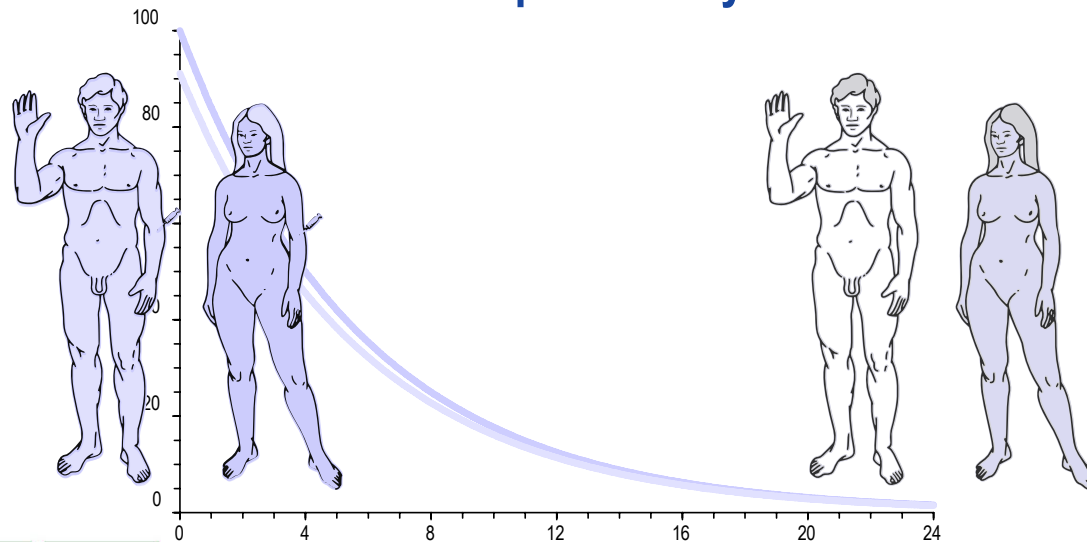

One compartment model, IV dose

Half life

- Throughout the profile concentration drops to $\frac{1}{2}$ of its previous value within one 'half life' ($t_{1/2}$).
- In a semilogarithmic plot the profile shows a straight line with
 - a slope of $-\ln(2)/t_{1/2}$, which is the elimination rate constant k_e and
 - the intercept is related to the initial concentration by $C_0 = e^{\text{intercept}}$.

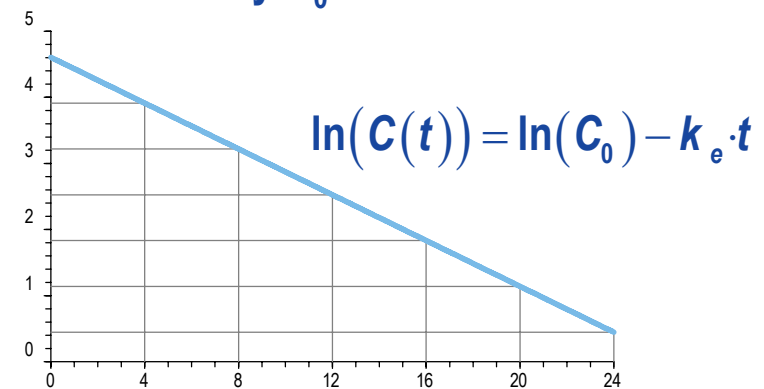
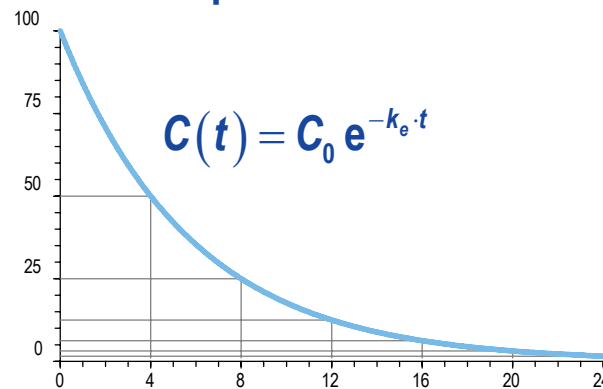

One compartment model, IV dose

Volume of distribution

- At administration the entire dose (D) is assumed to homogenously dissolve in the 'Volume of distribution' (V_d).
- We can only measure concentrations.
 - At $t = 0$ we get $V_d = \frac{C_0}{D}$.
 - Cave: V_d describes a *hypothetical* compartment, whereas in reality the distribution might not be homogenous. Some lipophilic drugs have a V_d of hundreds of liters...
 - Classical PK is *not* directly related to physiology.
 - Essentially, all models are wrong, but some are useful. *George Box*

One compartment model, IV dose

Clearance

- Instead of describing elimination by the rate constant k_e (unit: 1/time) we can also ask for the *fraction* of V_d which is completely 'cleared' of the drug per unit of time.
- This parameter is called 'Clearance' CL (unit: volume/time), which leads to basic equations of pharmacokinetics:

$$CL = V_d \cdot k_e \text{ or } \frac{D}{AUC}, \text{ where } AUC = \int_{t=0}^{t=\infty} C(t) dt$$

$$[\text{volume / time}] = \frac{[\text{mass}]}{[\text{time} \times \text{mass / volume}]}$$

PK Modeling

Model building process

- Define the model.
- This leads to a set of differential equations.
- The integrated form of the equations is used to fit the observed concentrations to the model.
- Once the model's parameters are obtained, we can make predictions.
- We can introduce covariates which may influence concentrations (e.g., body weight, age, sex, HCT, ...).
- We can try to link PK with pharmacodynamics – which regimen leads to an optimum effect?

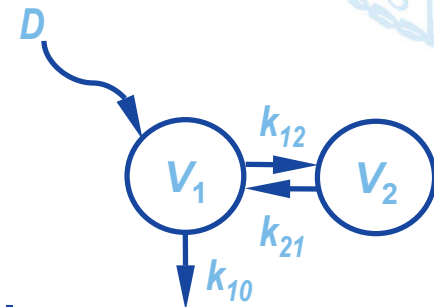

PK Modeling

Model building process

- Define the model
 - Compartments
 - Links between them
- This leads to a set of differential equations:

$$\begin{aligned}x_1'(t) &= -k_{10}x_1(t) - k_{12}x_1(t) + k_{21}x_2(t), & x_1(0) &= D \\x_2'(t) &= +k_{12}x_1(t) - k_{21}x_2(t), & x_2(0) &= 0\end{aligned}$$

- Simple ones can be solved mathematically.
- More complicated ones by means of 'Laplace Transformations'.
- Some can be only numerically integrated (software required).

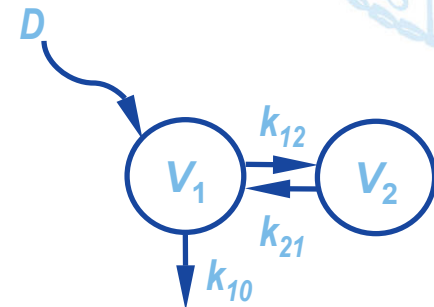

PK Modeling

Model building process

- The integrated form of the equations comes in two ‘flavors’
 - Micro-constants (volumes of distribution, rate constants or clearances)
 - One compartment IV bolus, parameterized in rate constant or clearance

$$\hat{C}(t) = \frac{D}{V} e^{-k_{10} \cdot t} \quad \text{or} \quad \hat{C}(t) = \frac{D}{V} e^{-\frac{CL \cdot t}{V}}$$

- Macro- or hybrid-constants (sum of exponentials)
- Two compartments IV bolus

$$\hat{C}(t) = A \cdot e^{-\alpha \cdot t} + B \cdot e^{-\beta \cdot t}$$

PK Modeling

Model building process

- Micro vs. macro...
 - The two parameterizations are equivalent, *i.e.*, they have a strict mathematical relationship – though the formulas relating them might be nasty (e.g., two-comp. IV micro → macro)

$$\alpha = \frac{1}{2} \left(k_{10} + k_{12} + k_{21} + \sqrt{(k_{10} + k_{12} + k_{21})^2 - 4k_{10}k_{21}} \right)$$

$$\beta = \frac{1}{2} \left(k_{10} + k_{12} + k_{21} - \sqrt{(k_{10} + k_{12} + k_{21})^2 - 4k_{10}k_{21}} \right)$$

$$A = \frac{D(\alpha - k_{21})}{V_1(\alpha - \beta)}$$

$$B = \frac{D(k_{21} - \beta)}{V_1(\alpha - \beta)}$$

PK Modeling

Model building process

- The integrated form of equations is used to fit the observed concentrations to the model
 - Different methods exist.
 - Most simple one:
Minimize the sum of least squares

$$\sum_{i=1}^{i=n} (C_i - \hat{C}_i)^2 \rightarrow \text{Min!}$$

where C_i are the *observed* and \hat{C}_i the *predicted* concentrations.

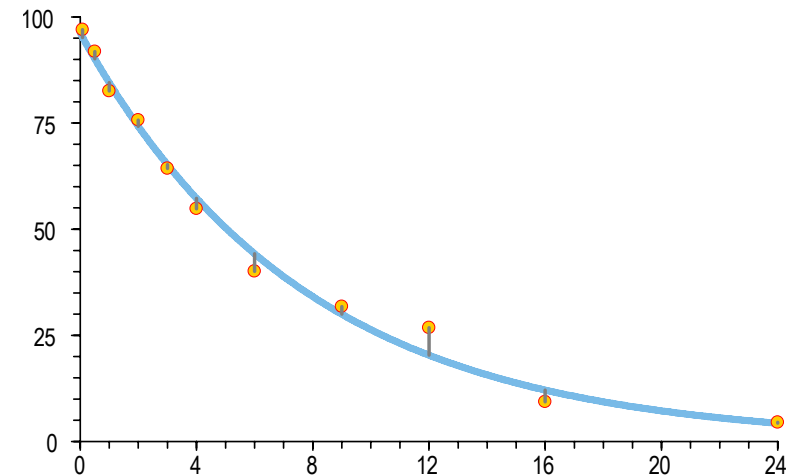

PK Modeling

Model building process

- Once the model's parameters are obtained, we can make predictions:
 - We can not only describe the time course of concentrations in plasma, but also in 'deeper' compartments and urine.
 - Derive suitable dosage regimens, e.g.,
 - Deal with accumulation,
 - Minimize fluctuations of concentrations in steady state,
 - Keep minimum concentrations above a threshold, ...
- We can assess whether patients' metrics influence concentrations. Examples:
 - Volume of distribution generally increases with body weight: $C \downarrow$
 - Clearance may decrease with age: $C \uparrow$

Interludes

Rate of drug input

- Average concentrations and the *AUC* are *independent* from the input-rate. Only maximum concentrations – and therefore, fluctuations in steady state – are affected.

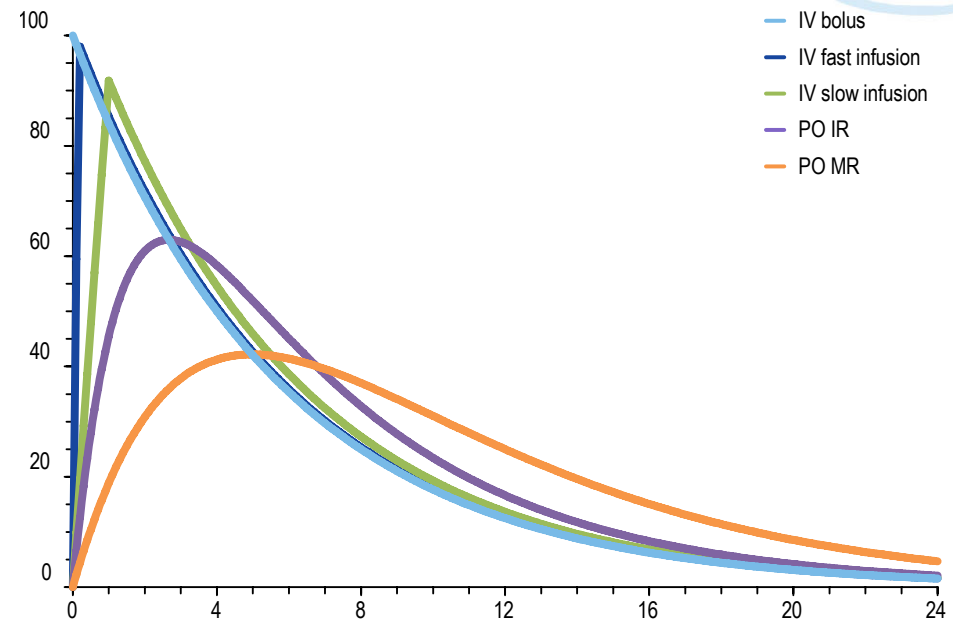

Interludes

Dost's 'Law of Corresponding Areas' aka 'Superposition Principle'

- In a linear PK system the Area Under the Curve in steady state within one dosing interval ($AUC_{0-\tau}$) equals $AUC_{0-\infty}$ after a single dose.

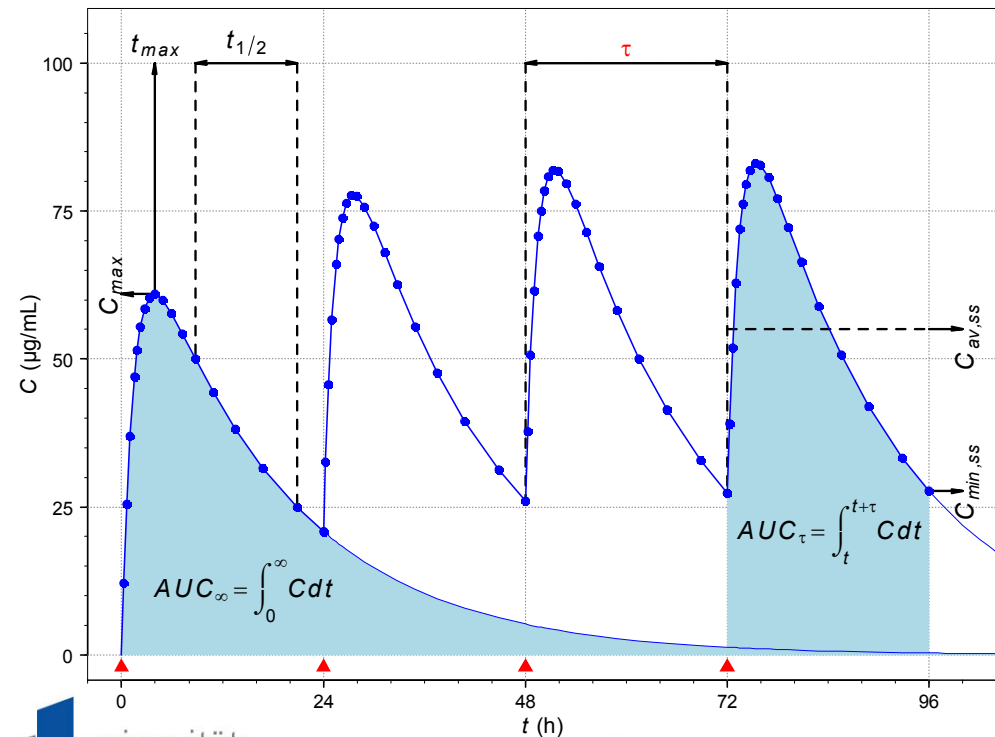

Interludes

Relevance of phases

- Generally the slowest phase is responsible for accumulation. Commonly ‘terminal half life’ is used synonymously with ‘biological half life’. However, sometimes the slow phase is not relevant.
- In any multi-compartment model (parameterized in macro-constants) the *AUC* is given as

$$AUC_{0-\infty} = \sum_{i=1}^{i=n} \frac{X_i}{\lambda_i}$$

where X_i are the coefficients and λ_i the exponents.

Interludes

Relevance of phases

- In the example all parameters are identical, except A and B ($A + B$ is kept constant).
- $AUC_{0-\infty}$ are identical.
- However, the slow phases account for **71%**, **91%**, and **98%** of $AUC_{0-\infty}$.

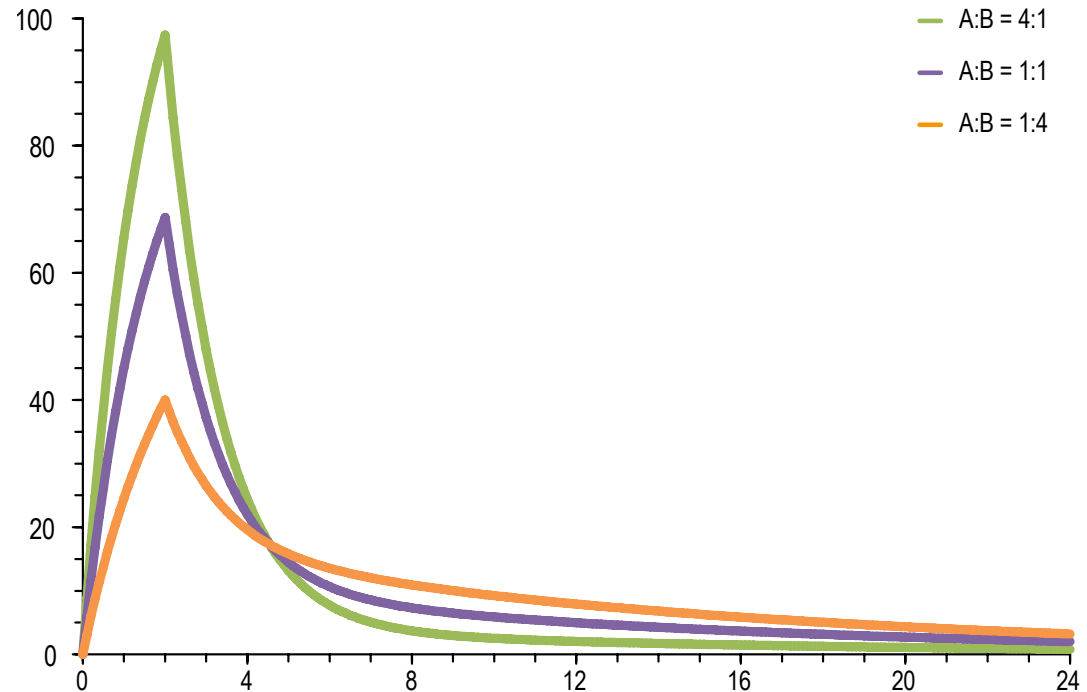

Interludes

Mean of Residence Times

- **Distribution and elimination are stochastic processes.**
 - Some molecules leave the circulation very quickly, whereas others stay for a long time.
 - Example
 - We dose 2000 IU (activity 4.5 MIU/mg) of FVIII (265 kDa) which will be eliminated with a half life of twelve hours. 1.67 nmol are $\approx 10^{15}$ (one quadrillion = 1 000 000 000 000 000!) molecules. If we could 'tag' individual molecules, we would see the first ones already leaving the central circulation within ~2 minutes. However, most stay longer...
 - If we register how long each molecule stays in the body (*i.e.*, their 'residence times') we could draw a histogram – like for any other distribution.

Interludes

Mean of Residence Times

- This histogram is actually the concentration-time curve.
- Distributions can be described by their so-called ‘statistical moments’.

- The ‘zero’ moment is given as

$$S_0 = \int f(x) dx$$

- The first as

$$S_1 = \int x \cdot f(x) dx$$

- The second as

$$S_2 = \int x^2 \cdot f(x) dx$$

Interludes

Mean of Residence Times

- In pharmacokinetics $S_0 = AUC$ and $S_1 = AUMC$, the 'Area Under the Moment Curve'.
- The 'Mean of Residence Times' is calculated as
 - $MRT = AUMC / AUC$
(IV and EV administration)
 - $MRT = AUMC / AUC - \frac{1}{2}t^*$
(infusion, where t^* = length of infusion)
- Rule of thumb: after MRT $\sim 2/3$ of the drug have been eliminated.
- S_2 is rarely used (leads to VRT, the 'Variance of Residence Times').

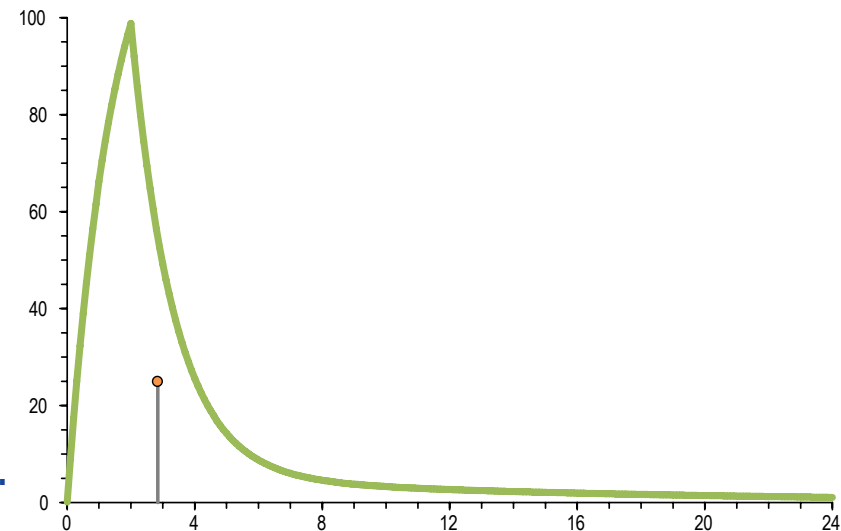

Two-Stage Procedure

In general we are not interested in describing the PK of *one particular* patient, but at least the *group* of patients in a study.

- Stage 1
 - Fit individual patients to a model.
 - Derive a set of PK parameters.
- Stage 2
 - From this set of PK parameters calculate means and standard deviations.
 - Optionally calculate a confidence interval which we can use in predicting what to expect in the *population* of patients.

Two-Stage Procedure

Problems

- *Which mean?*
 - Many biologic variables *do not* follow a normal distribution.
 - *Geometric mean:*
Clearances, volumes.
 - *Harmonic mean:*
Rate constants.
 - *Arithmetic mean:*
Excreted amounts.

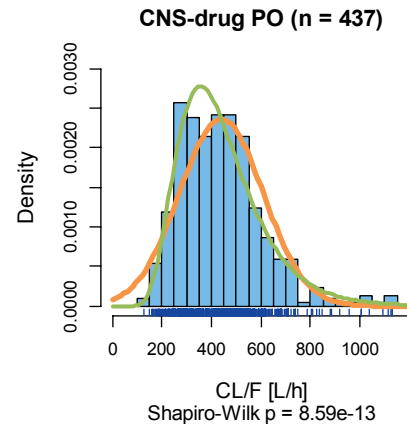

Normal Q-Q Plot

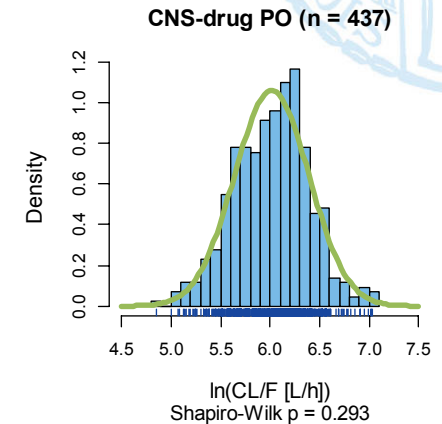
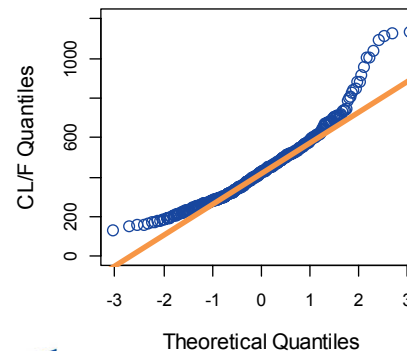

Normal Q-Q Plot

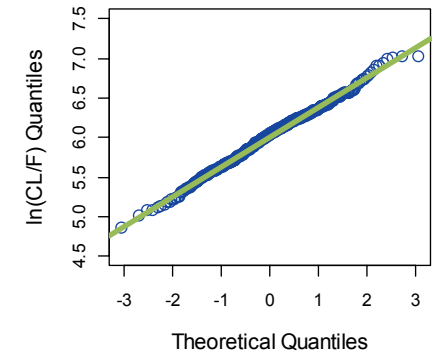

Two-Stage Procedure



Problems

- What if patients are best fit to *different* models?
 - Patients may belong to different genotypes (e.g., extensive and poor metabolizers).
 - Due to limitations of the bioanalytical method the ‘slow’ phase is not observed in EMs.
 - Best fits are a one-comp. model for the EM and a two-comp. model for the PM.

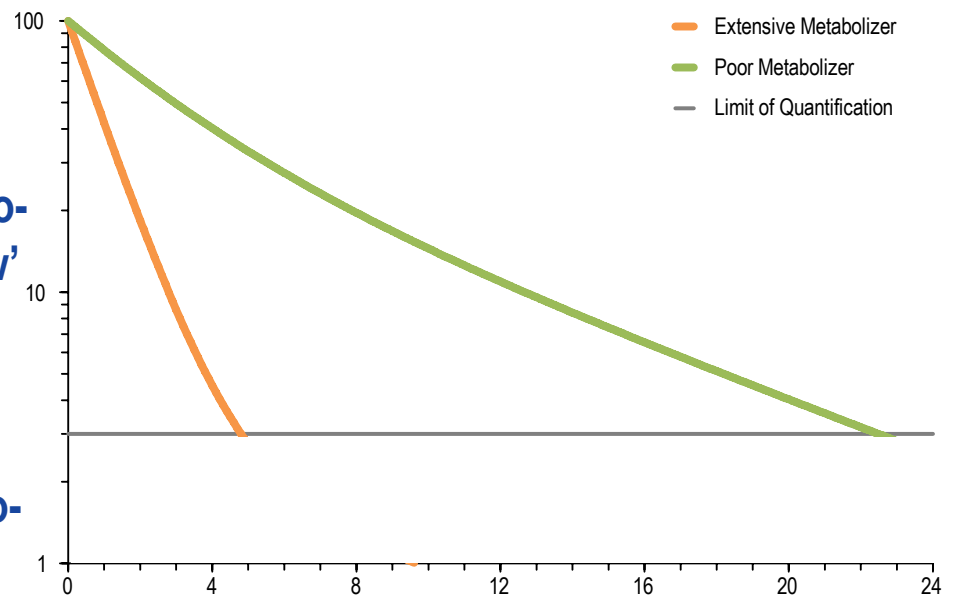

Two-Stage Procedure

Problems

- What if patients are best fit to *different* models?
 - Although eliminations are identical (parallel lines in the last phase) – we don't see it in the EM.
 - The model of the PM has five parameters (V_1 , V_2 , k_{10} , k_{12} , k_{21}), but the EM's model only two (V_1 , k_{10}).
 - It does not make sense to calculate means – 'apples and oranges'...

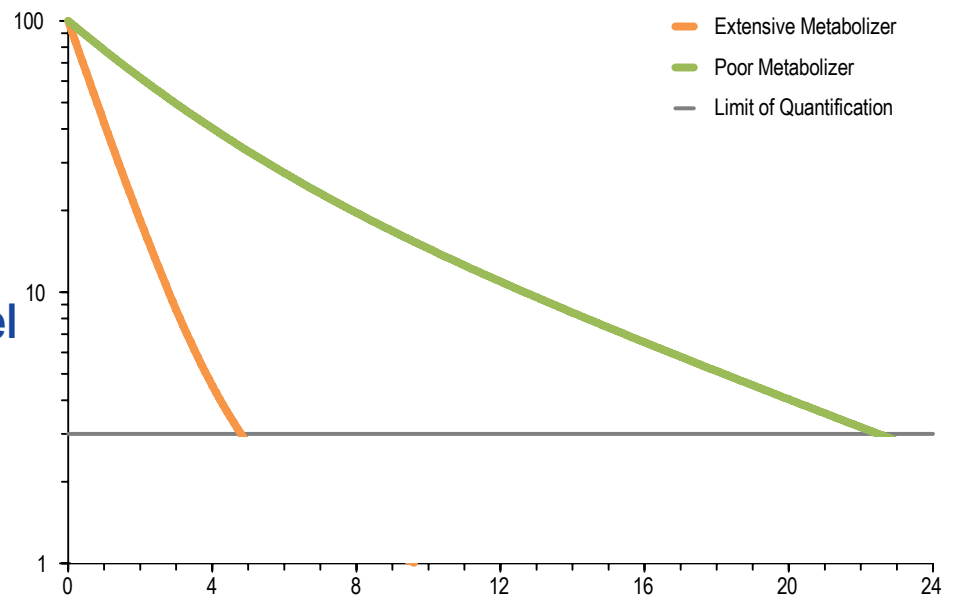

Population PK Modeling

Problems in the Two-Stage Procedure lead in the early 1970s to 'Population PK Modeling'

- Simultaneous fit of all patients' data
 - Separation of residual error into intra- and inter-individual components.
 - Direct assessment of covariates (body weight, age, sex, HCT, ...).
- PK of an 'average patient' is derived
 - Taking variabilities into account we can predict the PK of the entire *population* of patients.
 - Since covariates are already part of the model, we can predict the PK of a *particular patient* based upon them.

Population PK Modeling

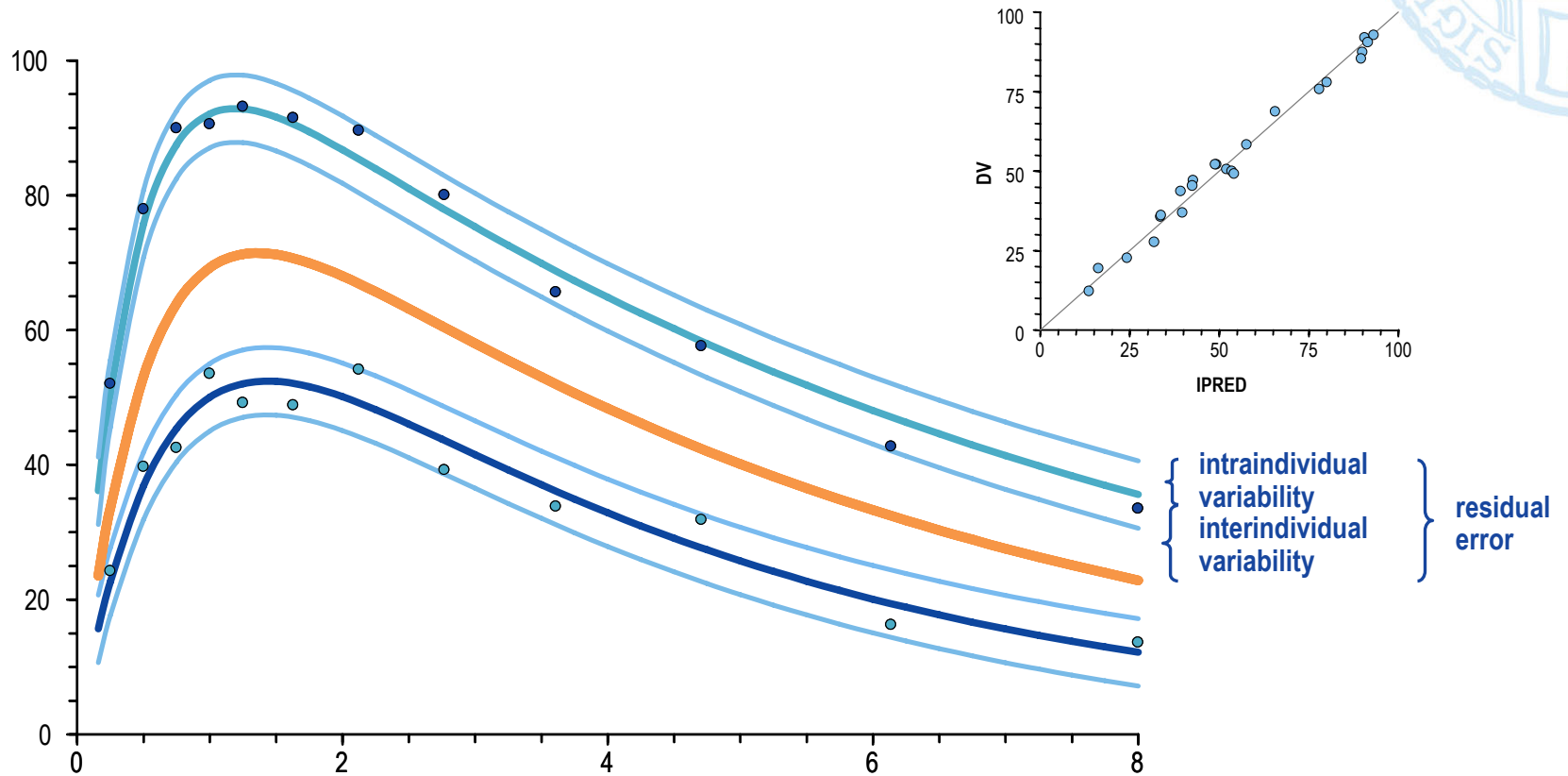

Population PK Modeling



Basics

- **Nonlinear Mixed Effects Model**
 - *Mixed Effects Model: Fixed and Random Effects*
- **Estimates Population PK parameters (V , CL , ...)**
 - Fixed Effects (thetas θ)
- **Estimates Variability**
 - Random Effects (etas η)
 - Intersubject Variability
 - Interoccasion Variability (day to day)
 - It is expected that etas are distributed $N(0, \omega^2)$.

Population PK Modeling



Basics

- **Estimates Variability (cont'd)**
 - Residual Error (epsilons ε)
 - Intrasubject: Measurement error, model misspecification, ...
 - It is expected that epsilons are distributed $N(0, \sigma^2)$.
- **Identify factors determining intersubject Variability: Covariates**
 - Demographics: Body weight / surface area, age, sex, ...
 - Genotypes: CYP450, ...
 - Physiology: Renal (creatinine clearance) or hepatic impairment, HCT, disease state, ...
 - Influence of concomitantly administered drugs (DDI)
 - Others: Food, circadian variation, formulation, ...

Population PK Modeling



Model

- $y_{ij} = f(\Theta_i) + \varepsilon_{ij}$, where
 - y_{ij} is the j^{th} observation of the i^{th} subject,
 - f is a model that describes all observations,
 - Θ_i is a vector of subject i 's parameter values (θ), and
 - ε_{ij} is the residual error of subject i 's j^{th} observation.
- The elements of Θ_i are usually $\theta_i = \theta \cdot e^{\eta}$, where
 - θ is the typical value for a parameter and
 - ω^2 is the variance of η values.

Pyry Väilitalo, University of Kuopio, 1.10.2009



ST. JAMES'S
HOSPITAL



Population PK Modeling

Components

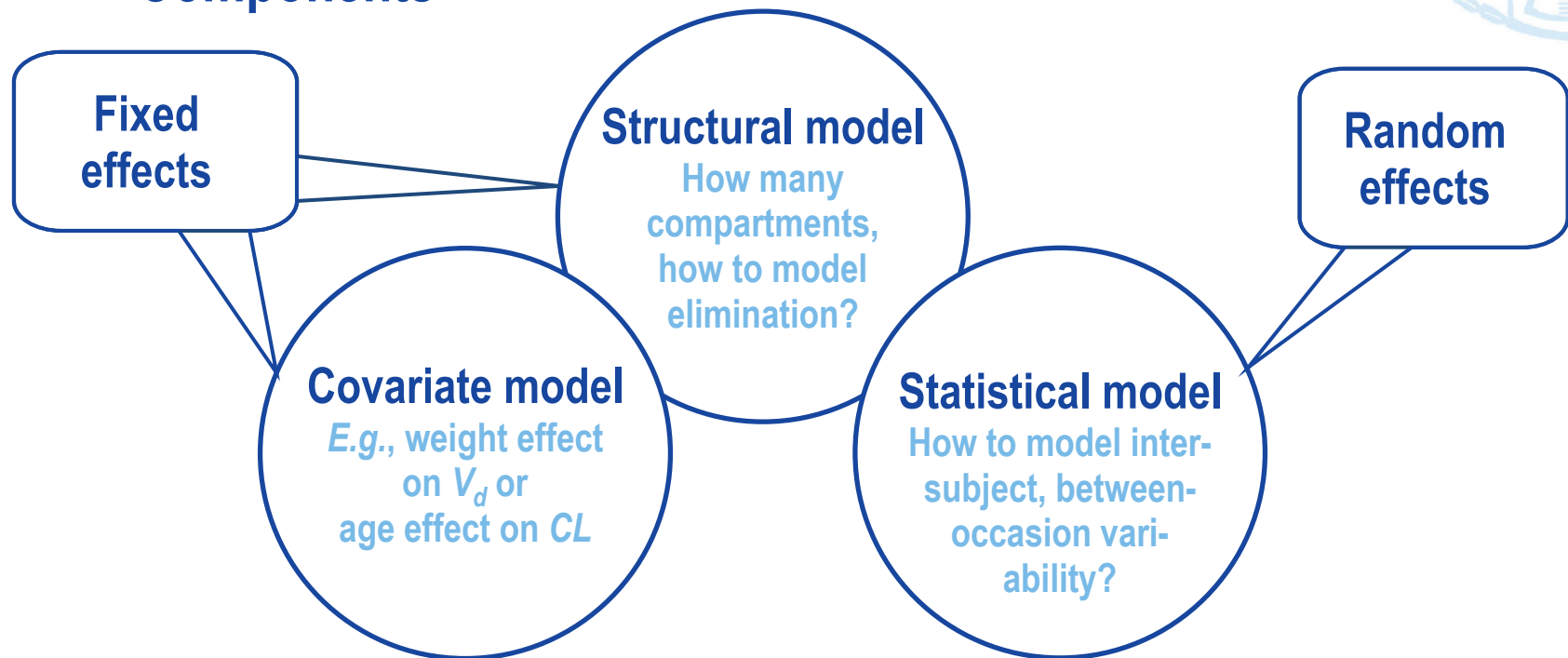

Pyy Väitalo, University of Kuopio, 1.10.2009

Population PK Modeling



Advantages

- **Studies in the target population**
- **Sparse sampling (only 2 – 3 samples / subject) possible**
 - Routine sampling in Phase II/III.
 - Special populations (Pediatrics, cancer/AIDS, hemophilia, critical care patients, elderly, ...).
- **Unlike in 'rich data sets' missing data not problematic**
 - Imbalanced designs common
 - Different doses / subject.
 - Different number of samples / subject.
 - Different sampling times / subject.

Population PK Modeling



Advantages

- **Covariates part of the model**
 - Fewer restrictions on in-/exclusion criteria.
 - ‘What if’ scenarios in planing further studies.
 - Full model allows prediction of ‘real world PK’ – leads to more reliable dose regimen / posology.
 - An established and fully validated PopPK model allows precise dosing of individual patients – leading to *personalized medicine*.

Population PK Modeling

Disadvantages

- **Complex methodology**
 - Might require simulations (optimal sampling times for sparse sampling); stepwise refinement of model during study.
 - Statistical models not trivial.
 - Expensive software with steep learning curve.
 - Carl Metzler: *“PK Modeling – Art or Science?”*
- **Time consuming**
 - Easily ~10times longer than classical Two-Stage PK – even for an experienced modeler.

Population PK Modeling



Disadvantages

- **Validation might require multiple studies**
 - **Internal validation:**
Use only a part of the study's data to set up a model and compare predictions with the other part.
 - **External validation:**
Predictions vs. another study
- **Cost/Benefit ratio**
 - Unclear beforehand whether the model will give more than a trivial result (like: concentrations depend on body weight).

Population PK Modeling

Example

- ADVATE, 19 patients, short infusion, rich data set, 2-comp model, covariates: age on V_1 , CL and body weight on V_1 , V_2 , CL ; FOCE ELS

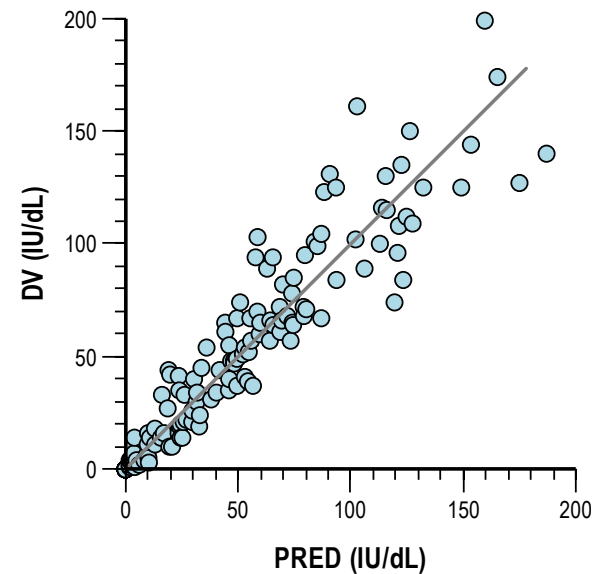
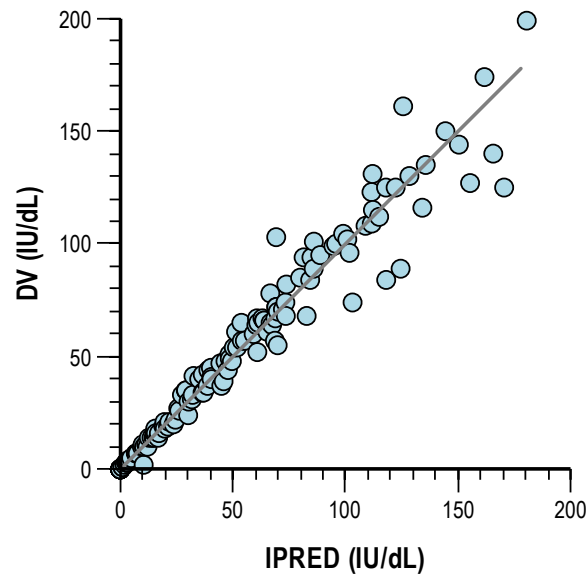

Pharmacokinetic Issues



Thank You!
Open Questions?



Helmut Schütz
BEBAC

Consultancy Services for
Bioequivalence and Bioavailability Studies
1070 Vienna, Austria
helmut.schuetz@bebac.at



ST. JAMES'S
HOSPITAL



Baxter

PopPK References

Sheiner LB, Rosenberg B, and KL Melmon

Modelling of individual pharmacokinetics for computer-aided drug dosage

Comput Biomed Res 5(5), 441-59 (1972)

Sheiner LB and SL Beal

NONMEM Users Guide

San Francisco: Division of Pharmacology: Univ. of California (1979)

Sheiner LB and SL Beal

Evaluation of methods for estimating population pharmacokinetics parameters. I. Michaelis-Menten model: routine clinical pharmacokinetic data

J Pharmacokin Biopharm 8(6), 553-71 (1980)

Sheiner LB and SL Beal

Evaluation of methods for estimating population pharmacokinetic parameters. II. Biexponential model and experimental pharmacokinetic data

J Pharmacokin Biopharm 9(5), 635-51 (1981)

Sheiner LB and SL Beal

Some suggestions for measuring predictive performance

J Pharmacokin Biopharm 9(4), 503-12 (1981)

Beal SL and LB Sheiner

Estimating population kinetics

Crit Rev Biomed Eng 8(3), 195-222 (1982)

Sheiner LB and SL Beal

Evaluation of methods for estimating population pharmacokinetic parameters. III. Monoexponential model: routine clinical pharmacokinetic data

J Pharmacokin Biopharm 11(3), 303-19 (1983)

A Mallet

A maximum likelihood estimation method for random coefficient regression models

Biometrika 73(3), 645-56 (1986)

Sheiner LB and SL Beal

A note on confidence intervals with extended least squares parameter estimation

J Pharmacokin Biopharm 15(1), 93-8 (1987)

Mallet A, Mentré F, Gilles J, Kelman AW, Thomson AH, Bryson SM, and B Whiting

Handling covariates in population pharmacokinetics, with an application to gentamicin

Biomed Meas Infor Contr 3, 138-46 (1988)

Lindstrom M and D Bates

Nonlinear Mixed Effects Models for Repeated Measures Data

Biometrics 46(3), 673-87 (1990)

Gelfand AE and AFM Smith

Sampling-Based Approaches to Calculating Marginal Densities

J Am Stat Assoc 85(410), 398-409 (1990)

PopPK References

Thomas A, Spiegelhalter DJ, and WR Gilks

BUGS: a program to perform Bayesian inference using Gibbs sampling.

In: *Bayesian Statistics*, Bernardo JM, Berger JO, Dawid AP, and AFM Smith (eds), vol. 4

Oxford University Press: Oxford, UK, 837–42 (1992)

Mentré F and R Gomeni

A two-step iterative algorithm for estimation in nonlinear mixed-effect models with an evaluation in population pharmacokinetics

J Biopharm Stat 5(2), 141–58 (1995)

Pinheiro J and D Bates

Mixed-Effects Models in S and S-PLUS

Springer: New York, USA (2000)

Beal SL, Sheiner LB, and AJ Boeckmann

NONMEM users guides (1989–2006)

icon development solutions: Ellicott City, MD, USA

Zhang L, Beal SL, and LB Sheiner

Simultaneous vs. sequential analysis for population PK/PD data I: best-case performance

J Pharmacokinet Pharmacodyn 30(6), 387–404 (2003)

Zhang L, Beal SL, and LB Sheiner

Simultaneous vs. sequential analysis for population PK/PD data I: robustness of methods

J Pharmacokinet Pharmacodyn 30(6), 405–16 (2003)

Kuhn E and M Lavielle

Maximum likelihood estimation in nonlinear mixed effects models

Comput Stat Data Anal 49(4), 1020–38 (2005)

Girard P and F Mentré

A comparison of estimation methods in nonlinear mixed effects models using a blind analysis

PAGE Meeting: Pamplona, Spain (16–17 June 2005)

<http://www.page-meeting.org/page/page2005/PAGE2005O08.pdf>

DJ Lunn

Bayesian analysis of population pharmacokinetic / pharmacodynamic models. In: *Probabilistic Modeling in Bioinformatics and Medical Informatics*,

Husmeier D, Dybowski R and S Roberts (eds).

Springer: London, UK, 351–70 (2005)

Bauer RJ, Guzy S, and C Ng

A survey of population analysis methods and software for complex pharmacokinetic and pharmacodynamic models with examples

AAPS J 9(1), E60–83 (2007)

Lunn D et al.

The BUGS project: Evolution, critique and future directions

Statist Med 28(25), 3049–188 (2009)

[DOI: 10.1002/sim.3680](https://doi.org/10.1002/sim.3680)



ST. JAMES'S
HOSPITAL



Baxter

PopPK References

Lunn D *et al.*

Combining MCMC with 'sequential' PKPD modelling

J Pharmacokinet Pharmacodyn 36(1), 19–38 (2009)

DOI: [10.1007/s10928-008-9109-1](https://doi.org/10.1007/s10928-008-9109-1)

Pandhard X and A Samson

Extension of the SAEM algorithm for nonlinear mixed models with 2 levels of random effects

Biostatistics 10(1), 121–35 (2009)

P Bonate

Pharmacokinetic-Pharmacodynamic Modeling and Simulation

Springer Verlag: New York, USA (2nd ed. 2011)

Neely MN *et al.*

Accurate Detection of Outliers and Subpopulations With Pmetrics, a Nonparametric and Parametric Pharmacometric Modeling and Simulation Package for R

Therapeutic Drug Monitoring 34(4), 467–76 (2012)

Chan PLS *et al.*

The use of the SAEM algorithm in MONOLIX software for estimation of population pharmacokinetic-pharmacodynamic-viral dynamics parameters of maraviroc in asymptomatic HIV subjects

J Pharmacokinet Pharmacodyn 38(4), 41–61 (2011)

DOI: [10.1007/s10928-010-9175-z](https://doi.org/10.1007/s10928-010-9175-z)

FDA/CDER/CBER

- *Guidance for Industry. Population Pharmacokinetics* (February 1999)
<http://www.fda.gov/downloads/Drugs/GuidanceComplianceRegulatoryInformation/Guidances/ucm072137.pdf>

EMA/CHMP

- *Guideline on the Role of Pharmacokinetics in the Development of Medicinal Products in the Paediatric Population*
EMA/CHMP/EWP/147013/2004 (June 2006)
http://www.ema.europa.eu/docs/en_GB/document_library/Scientific_guideline/2009/09/WC500003066.pdf
- *Guideline on Reporting the Results of Population Pharmacokinetic Analyses*
CHMP/EWP/185990/06 (June 2007)
http://www.ema.europa.eu/docs/en_GB/document_library/Scientific_guideline/2009/09/WC500003067.pdf